



Professional HEAVY DUTY

GKS 12V-26

Robert Bosch Power Tools GmbH
70538 Stuttgart
GERMANY

www.bosch-pt.com

1 609 92A 90Z (2026.02) 0 / 17



1 609 92A 90Z



en Original instructions





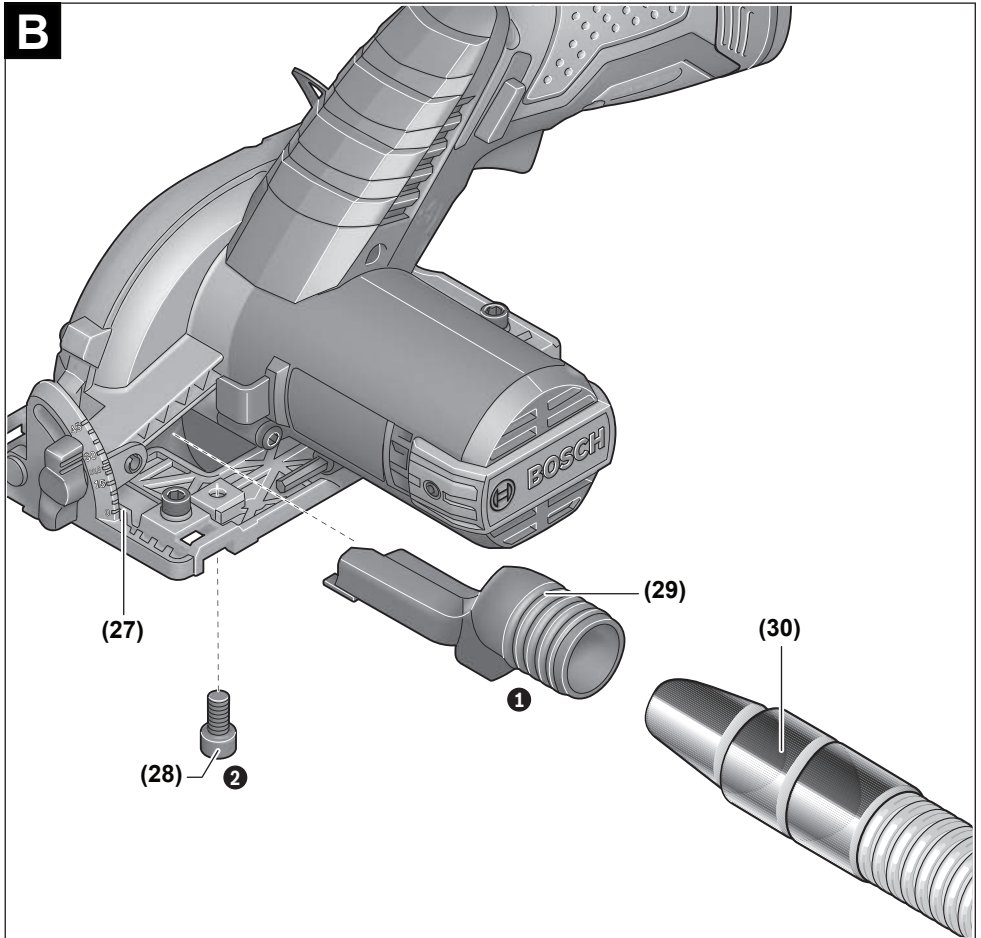
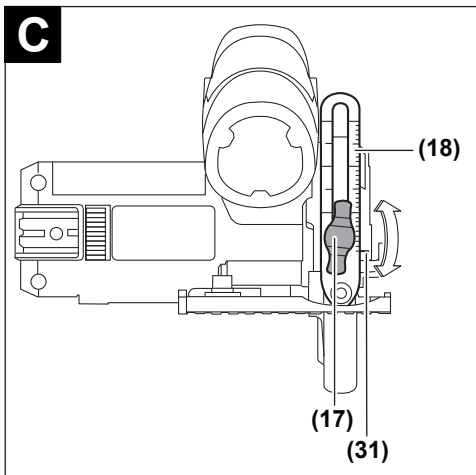
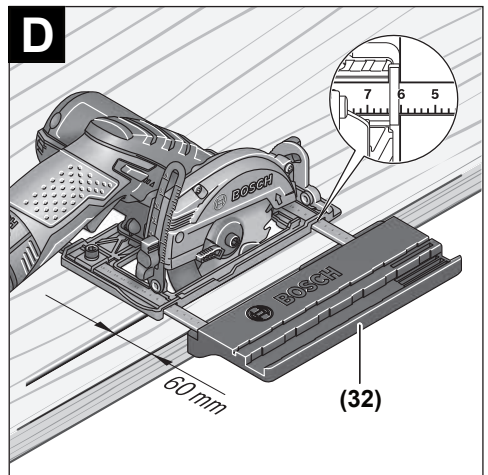

B**C****D**

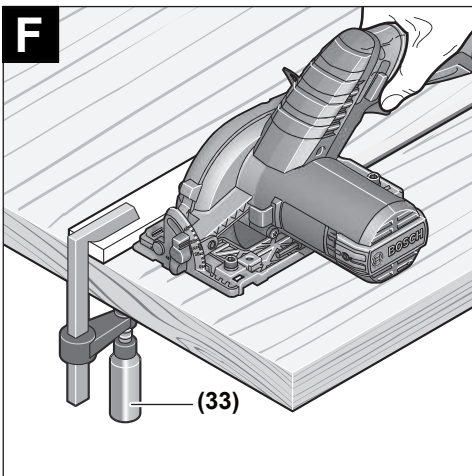
E**F**

English

Safety Instructions

General Power Tool Safety Warnings

⚠️ WARNING Read all safety warnings, instructions, illustrations and specifications provided with this power tool. Failure to follow all instructions listed below may result in electric shock, fire and/or serious injury.

Save all warnings and instructions for future reference.

The term "power tool" in the warnings refers to your mains-operated (corded) power tool or battery-operated (cordless) power tool.

Work area safety

- ▶ **Keep work area clean and well lit.** Cluttered or dark areas invite accidents.
- ▶ **Do not operate power tools in explosive atmospheres, such as in the presence of flammable liquids, gases or dust.** Power tools create sparks which may ignite the dust or fumes.
- ▶ **Keep children and bystanders away while operating a power tool.** Distractions can cause you to lose control.

Electrical safety

- ▶ **Do not expose power tools to rain or wet conditions.** Water entering a power tool will increase the risk of electric shock.

Personal safety

- ▶ **Stay alert, watch what you are doing and use common sense when operating a power tool. Do not use a power tool while you are tired or under the influence of drugs, alcohol or medication.** A moment of inattention while operating power tools may result in serious personal injury.
- ▶ **Use personal protective equipment. Always wear eye protection.** Protective equipment such as a dust mask, non-skid safety shoes, hard hat or hearing protection used for appropriate conditions will reduce personal injuries.
- ▶ **Prevent unintentional starting. Ensure the switch is in the off-position before connecting to power source and/or battery pack, picking up or carrying the tool.** Carrying power tools with your finger on the switch or engaging power tools that have the switch on invites accidents.
- ▶ **Remove any adjusting key or wrench before turning the power tool on.** A wrench or a key left attached to a rotating part of the power tool may result in personal injury.
- ▶ **Do not overreach. Keep proper footing and balance at all times.** This enables better control of the power tool in unexpected situations.

- ▶ **Dress properly. Do not wear loose clothing or jewellery. Keep your hair and clothing away from moving parts.** Loose clothes, jewellery or long hair can be caught in moving parts.
- ▶ **If devices are provided for the connection of dust extraction and collection facilities, ensure these are connected and properly used.** Use of dust collection can reduce dust-related hazards.
- ▶ **Do not let familiarity gained from frequent use of tools allow you to become complacent and ignore tool safety principles.** A careless action can cause severe injury within a fraction of a second.

Power tool use and care

- ▶ **Do not force the power tool. Use the correct power tool for your application.** The correct power tool will do the job better and safer at the rate for which it was designed.
- ▶ **Do not use the power tool if the switch does not turn it on and off.** Any power tool that cannot be controlled with the switch is dangerous and must be repaired.
- ▶ **Disconnect the plug from the power source and/or remove the battery pack, if detachable, from the power tool before making any adjustments, changing accessories, or storing power tools.** Such preventive safety measures reduce the risk of starting the power tool accidentally.
- ▶ **Store idle power tools out of the reach of children and do not allow persons unfamiliar with the power tool or these instructions to operate the power tool.** Power tools are dangerous in the hands of untrained users.
- ▶ **Maintain power tools and accessories. Check for misalignment or binding of moving parts, breakage of parts and any other condition that may affect the power tool's operation. If damaged, have the power tool repaired before use.** Many accidents are caused by poorly maintained power tools.
- ▶ **Keep cutting tools sharp and clean.** Properly maintained cutting tools with sharp cutting edges are less likely to bind and are easier to control.
- ▶ **Use the power tool, accessories and tool bits etc. in accordance with these instructions, taking into account the working conditions and the work to be performed.** Use of the power tool for operations different from those intended could result in a hazardous situation.
- ▶ **Keep handles and grasping surfaces dry, clean and free from oil and grease.** Slippery handles and grasping surfaces do not allow for safe handling and control of the tool in unexpected situations.

Battery tool use and care

- ▶ **Recharge only with the charger specified by the manufacturer.** A charger that is suitable for one type of battery pack may create a risk of fire when used with another battery pack.

- ▶ **Use power tools only with specifically designated battery packs.** Use of any other battery packs may create a risk of injury and fire.
- ▶ **When battery pack is not in use, keep it away from other metal objects, like paper clips, coins, keys, nails, screws or other small metal objects, that can make a connection from one terminal to another.** Shorting the battery terminals together may cause burns or a fire.
- ▶ **Under abusive conditions, liquid may be ejected from the battery; avoid contact. If contact accidentally occurs, flush with water. If liquid contacts eyes, additionally seek medical help.** Liquid ejected from the battery may cause irritation or burns.
- ▶ **Do not use a battery pack or tool that is damaged or modified.** Damaged or modified batteries may exhibit unpredictable behaviour resulting in fire, explosion or risk of injury.
- ▶ **Do not expose a battery pack or tool to fire or excessive temperature.** Exposure to fire or temperature above 130°C may cause explosion.
- ▶ **Follow all charging instructions and do not charge the battery pack or tool outside the temperature range specified in the instructions.** Charging improperly or at temperatures outside the specified range may damage the battery and increase the risk of fire.

Service

- ▶ **Have your power tool serviced by a qualified repair person using only identical replacement parts.** This will ensure that the safety of the power tool is maintained.
- ▶ **Never service damaged battery packs.** Service of battery packs should only be performed by the manufacturer or authorized service providers.

Safety instructions for circular saws

Cutting procedures

- ▶  **DANGER: Keep hands away from cutting area and the blade.** If both hands are holding the saw, they cannot be cut by the blade.
- ▶ **Do not reach underneath the workpiece.** The guard cannot protect you from the blade below the workpiece.
- ▶ **Adjust the cutting depth to the thickness of the workpiece.** Less than a full tooth of the blade teeth should be visible below the workpiece.
- ▶ **Never hold the workpiece in your hands or across your leg while cutting. Secure the workpiece to a stable platform.** It is important to support the work properly to minimise body exposure, blade binding, or loss of control.
- ▶ **Hold the power tool by insulated gripping surfaces, when performing an operation where the cutting tool may contact hidden wiring.** Contact with a "live" wire will also make exposed metal parts of the power tool "live" and could give the operator an electric shock.
- ▶ **When ripping always use a rip fence or straight edge guide.** This improves the accuracy of cut and reduces the chance of blade binding.
- ▶ **Always use blades with correct size and shape (diamond versus round) of arbour holes.** Blades that do not match the mounting hardware of the saw will run off-centre, causing loss of control.
- ▶ **Never use damaged or incorrect blade washers or bolt.** The blade washers and bolt were specially designed for your saw, for optimum performance and safety of operation.

Kickback causes and related warnings

- kickback is a sudden reaction to a pinched, jammed or misaligned saw blade, causing an uncontrolled saw to lift up and out of the workpiece toward the operator;
 - when the blade is pinched or jammed tightly by the kerf closing down, the blade stalls and the motor reaction drives the unit rapidly back toward the operator;
 - if the blade becomes twisted or misaligned in the cut, the teeth at the back edge of the blade can dig into the top surface of the wood causing the blade to climb out of the kerf and jump back toward the operator.
- Kickback is the result of saw misuse and/or incorrect operating procedures or conditions and can be avoided by taking proper precautions as given below.

- ▶ **Maintain a firm grip on the saw and position your arms to resist kickback forces. Position your body to either side of the blade, but not in line with the blade.** Kickback could cause the saw to jump backwards, but kickback forces can be controlled by the operator, if proper precautions are taken.
- ▶ **When blade is binding, or when interrupting a cut for any reason, release the trigger and hold the saw motionless in the material until the blade comes to a complete stop. Never attempt to remove the saw from the work or pull the saw backward while the blade is in motion or kickback may occur.** Investigate and take corrective actions to eliminate the cause of blade binding.
- ▶ **When restarting a saw in the workpiece, centre the saw blade in the kerf so that the saw teeth are not engaged into the material.** If a saw blade binds, it may walk up or kickback from the workpiece as the saw is restarted.
- ▶ **Support large panels to minimise the risk of blade pinching and kickback.** Large panels tend to sag under their own weight. Supports must be placed under the panel on both sides, near the line of cut and near the edge of the panel.
- ▶ **Do not use dull or damaged blades.** Unsharpened or improperly set blades produce narrow kerf causing excessive friction, blade binding and kickback.
- ▶ **Blade depth and bevel adjusting locking levers must be tight and secure before making the cut.** If blade adjustment shifts while cutting, it may cause binding and kickback.

- ▶ **Use extra caution when sawing into existing walls or other blind areas.** The protruding blade may cut objects that can cause kickback.

Lower guard function

- ▶ **Check the lower guard for proper closing before each use. Do not operate the saw if the lower guard does not move freely and close instantly. Never clamp or tie the lower guard into the open position.** If the saw is accidentally dropped, the lower guard may be bent. Raise the lower guard with the retracting handle and make sure it moves freely and does not touch the blade or any other part, in all angles and depths of cut.
- ▶ **Check the operation of the lower guard spring. If the guard and the spring are not operating properly, they must be serviced before use.** Lower guard may operate sluggishly due to damaged parts, gummy deposits, or a build-up of debris.
- ▶ **The lower guard may be retracted manually only for special cuts such as "plunge cuts" and "compound cuts". Raise the lower guard by the retracting handle and as soon as the blade enters the material, the lower guard must be released.** For all other sawing, the lower guard should operate automatically.
- ▶ **Always observe that the lower guard is covering the blade before placing the saw down on bench or floor.** An unprotected, coasting blade will cause the saw to walk backwards, cutting whatever is in its path. Be aware of the time it takes for the blade to stop after switch is released.

Additional safety warnings

- ▶ **Do not allow the chip ejector to come into contact with your hands.** You may be injured by rotating parts.
- ▶ **Do not use the saw above the level of your head.** Doing so will mean you have inadequate control of the power tool.
- ▶ **Use suitable detectors to determine if there are hidden supply lines or contact the local utility company for assistance.** Contact with electric cables can cause fire and electric shock. Damaging gas lines can lead to explosion. Breaking water pipes causes property damage.
- ▶ **Do not operate the power tool when stationary .** It is not suitable for operation with a saw table.
- ▶ **Secure the workpiece.** A workpiece clamped with clamping devices or in a vice is held more secure than by hand.
- ▶ **When performing plunge cuts which are not right-angled, secure the guide plate of the saw so that it will not shift sideways.** In the event of a sideways shift, the saw blade may become jammed, which could lead to kickback.
- ▶ **Do not use HSS saw blades.** Such saw blades can easily break.
- ▶ **Do not saw any ferrous metals.** Hot chips may ignite the dust extractor.
- ▶ **Wear a dust mask.**

- ▶ **In case of damage and improper use of the battery, vapours may be emitted. The battery can set alight or explode.** Ensure the area is well ventilated and seek medical attention should you experience any adverse effects. The vapours may irritate the respiratory system.
- ▶ **Do not modify or open the battery.** There is a risk of short-circuiting.
- ▶ **The battery can be damaged by pointed objects such as nails or screwdrivers or by force applied externally.** An internal short circuit may occur, causing the battery to burn, smoke, explode or overheat.
- ▶ **Only use the battery in the manufacturer's products.** This is the only way in which you can protect the battery against dangerous overload.



Protect the battery against heat, e.g. against continuous intense sunlight, fire, dirt, water and moisture. There is a risk of explosion and short-circuiting.



- ▶ **Always wait until the power tool has come to a complete stop before placing it down.** The application tool can jam and cause you to lose control of the power tool.

Product Description and Specifications



Read all the safety and general instructions.

Failure to observe the safety and general instructions may result in electric shock, fire and/or serious injury.

Please observe the illustrations at the beginning of this operating manual.

Intended use

The power tool is intended for making straight cuts in wood with and against the grain and mitre cuts in wood while resting firmly against the workpiece.

Product features

The numbering of the product features refers to the diagram of the power tool on the graphics page.

- (1) Battery
- (2) Battery release button
- (3) Lock-off button for on/off switch
- (4) On/off switch
- (5) Hex key
- (6) Spindle lock button
- (7) Base plate
- (8) Fastening screw for parallel guide
- (9) Scale for mitre/bevel angles
- (10) Wing bolt for mitre/bevel angle preselection
- (11) Cut mark 45°
- (12) Cut mark 0°
- (13) Protective guard

- (14) Handle (insulated gripping surface)
- (15) Battery charge indicator
- (16) Temperature monitoring/overload protection indicator
- (17) Wing bolt for preselecting the cutting depth
- (18) Cutting depth scale
- (19) Adjusting lever for retracting blade guard
- (20) Saw spindle
- (21) Retracting blade guard
- (22) Mounting flange
- (23) Circular saw blade
- (24) Clamping flange
- (25) Clamping bolt
- (26) "PowerLight" lamp
- (27) Reference mark for mitre angle setting
- (28) Fastening screw for dust extraction adapter^{a)}
- (29) Dust extraction adapter^{a)}
- (30) Dust extraction hose^{a)}
- (31) Reference mark for cutting depth setting
- (32) Parallel guide/guide rail adapter^{a)}
- (33) Pair of screw clamps^{a)}
- (34) Guide rail^{a)}

a) **This accessory is not part of the standard scope of delivery.**

Technical data

Circular Saw		GKS 12V-26
Article number		3 601 FA1 0..
Rated voltage	V $\overline{}$	12
Rated no-load speed ^{A)}	min ⁻¹	1400
Max. cutting depth		
– at a 0° mitre/bevel angle	mm	26.5
– At a 45° mitre/bevel angle	mm	17.0
Spindle lock		●
Base plate dimensions	mm	167 x 88
Max. saw blade diameter	mm	85
Min. saw blade diameter	mm	85
Max. base blade thickness	mm	1.0
Max. tooth thickness/offset	mm	1.5
Min. tooth thickness/offset	mm	1.0
Locating bore	mm	15
Weight ^{B)}	kg	1.1
Recommended ambient temperature during charging	°C	0 to +35
Permitted ambient temperature during operation ^{C)} and during storage	°C	-20 to +50

Circular Saw		GKS 12V-26
Recommended rechargeable batteries		GBA 12V...
Recommended battery chargers		GAL 12... GAX 18...

A) Measured at 20–25 °C with rechargeable battery **GBA 12V 2.0 Ah**

B) Without rechargeable battery (you can find the battery weight at www.bosch-professional.com)

C) Limited performance at temperatures < 0 °C

Values can vary depending on the product, scope of application and environmental conditions. To find out more, visit www.bosch-professional.com/wac.

Noise/vibration information

Noise emission values determined according to

EN 62841-2-5.

Typically, the A-weighted noise level of the power tool is: Sound pressure level **82 dB(A)**; sound power level **93 dB(A)**. Uncertainty K = **3 dB**.

Wear hearing protection!

Vibration values a_h (continuous vibrations), p_r (repeated shock vibrations) and uncertainty K determined according to **EN 62841-2-5**:

Cutting wood: $a_{h,W} = 0.7 \text{ m/s}^2$ (K = **1.5 m/s}^2**),

$p_{r,W} = 55 \text{ m/s}^2$ (K = **6 m/s}^2**)

The vibration level and noise emission value given in these instructions have been measured in accordance with a standardised measuring procedure and may be used to compare power tools. They may also be used for a preliminary estimation of vibration and noise emissions.

The stated vibration level and noise emission value represent the main applications of the power tool. However, if the power tool is used for other applications, with different accessories or is poorly maintained, the vibration level and noise emission value may differ. This may significantly increase the vibration and noise emissions over the total working period.

To estimate vibration and noise emissions accurately, the times when the tool is switched off or when it is running but not actually being used should also be taken into account. This may significantly reduce vibration and noise emissions over the total working period.

Implement additional safety measures to protect the operator from the effects of vibration, such as servicing the power tool and accessories, keeping their hands warm, and organising workflows correctly.

Rechargeable battery

Bosch sells some cordless power tools without a rechargeable battery. You can tell whether a rechargeable battery is included with the power tool by looking at the packaging.

Charging the battery

- ▶ **Use only the chargers listed in the technical data.** Only these chargers are matched to the lithium-ion battery of your power tool.

Note: Lithium-ion rechargeable batteries are supplied partially charged according to international transport regulations. To ensure full rechargeable battery capacity, fully charge the rechargeable battery before using your tool for the first time.

Inserting the Battery

Push the charged battery into the battery holder until it clicks into place.

Removing the Battery

To remove the rechargeable battery, press the battery release buttons and pull the battery out. **Do not use force to do this.**

Battery charge indicator

The battery charge indicator indicates the state of charge for a few seconds when the on/off switch is pressed halfway.

LED	Capacity
3× continuous green light	60–100 %
2× continuous green light	30–60 %
1× continuous green light	5–30 %
1× flashing green light	0–5 %

Temperature monitoring/overload protection indicator

The red LED indicator helps you to protect the rechargeable battery against overheating and the motor against overload.

If the LED indicator is lit up **permanently in red**, the temperature of the rechargeable battery is too high and the power tool switches off automatically.

- Switch the power tool off.
- Allow the battery to cool down before you carry on working.

If the LED indicator is **flashing red**, then the power tool is blocked and will switch off automatically.

Pull the power tool out of the workpiece.

The power tool will continue to work as soon as the blockage is rectified.

Recommendations for Optimal Handling of the Battery

Protect the battery against moisture and water.

Only store the battery within a temperature range of –20 to 50 °C. Do not leave the battery in your car in the summer, for example.

Occasionally clean the ventilation slots on the battery using a soft brush that is clean and dry.

A significantly reduced operating time after charging indicates that the battery has deteriorated and must be replaced.

Follow the instructions on correct disposal.

Fitting

- ▶ **Only use saw blades the maximum permitted speed of which is higher than the no-load speed of the power tool.**

Inserting/changing the circular saw blade

- ▶ **Remove the battery before carrying out any work on the power tool.**
- ▶ **Wear protective gloves when fitting the saw blade.**
Danger of injury when touching the saw blade.
- ▶ **Only use saw blades that match the specifications given in this operating manual and on the power tool and that have been tested and marked in accordance with EN 847-1:2017.**
- ▶ **The permitted speed of the application tool must be at least equal to the maximum speed marked on the power tool.** If accessories run faster than their rated speed, they may break and fly off.
- ▶ **Do not use abrasive wheels as the application tool under any circumstances.**

Selecting the saw blade

You will find an overview of recommended saw blades at the end of these operating instructions.

Removing the Saw Blade (see figure A)

To change tools, we recommend that you place the power tool down on the front side of the motor housing.

- Press and hold the spindle lock button (6).
- ▶ **Do not press the spindle lock button (6) while the saw spindle is moving.** The power tool may become damaged if this happens.
- Use the hex key (5) to undo the clamping bolt (25) in rotational direction ①.
- Swing the retracting blade guard (21) back and hold on to it firmly.
- Remove the clamping flange (24) and the saw blade (23) from the saw spindle (20).

Mounting the Saw Blade (see figure A)

To change tools, we recommend that you place the power tool down on the front side of the motor housing.

- Clean the saw blade (23) and all the clamping elements to be fitted.
- Swing the retracting blade guard (21) back and hold on to it firmly.
- Place the saw blade (23) on the mounting flange (22). The cutting direction of the teeth (direction of the arrow on the saw blade) must match the rotational direction of the arrow on the protective guard (21).
- Attach the clamping flange (24) and screw in the clamping bolt (25) in rotational direction ②. Ensure that the mounting flange (22) and clamping flange (24) are installed in the correct position.
- Press and hold the spindle lock button (6).

- Use the hex key (5) to tighten the clamping bolt (25) in rotational direction . The tightening torque should be 6–9 Nm, which corresponds to hand-tight plus ¼ turn.

Dust/Chip Extraction

Do not perform work without taking dust-reducing measures.

Using a suitable dust extraction attachment or a dust box/dust bag will reduce exposure to harmful dust. Provide good ventilation at the workplace. Always use suitable breathing protection. If you are using a dust box, empty it in good time and clean the filter element regularly to ensure optimal dust extraction.

If you are using a dust extractor, refer to the requirements listed below. The regulations on the material being machined that apply in the country of use must be observed.

- ▶ **Avoid dust accumulation at the workplace.** Dust can easily ignite.

Requirements for the Dust Extractor		
Recommended hose nominal diameter	mm	35
Required vacuum pressure ^{A)}	mbar	≥ 230
	hPa	≥ 230
Required flow rate ^{A)}	l/s	≥ 36
	m³/h	≥ 129.6
Recommended filter efficiency	Dust class M ^{B)}	

A) Power value at the power tool's dust extractor connection

B) According to IEC/EN 60335-2-69

Refer to the dust extractor's instructions. If there is reduced suction power, stop working and eliminate the cause.

Fitting the dust extraction adapter (see figure B)

Fasten the dust extraction adapter (29) to the base plate (7) using the fastening screw (28).

A dust extraction hose with a diameter of 19 mm can be connected to the dust extraction adapter (29).

- ▶ **The dust extraction adapter must only be fitted if an external dust extraction system is connected.** Otherwise the extraction duct can become clogged.
- ▶ **No dust bags should be connected to the dust extraction adapter.** Otherwise the extraction system can become clogged.

To ensure optimum extraction, the dust extraction adapter (29) must be cleaned regularly.

External dust extraction

Connect the extraction hose (30) to a dust extractor (accessory). You will find an overview of connecting to various dust extractors at the end of these operating instructions.

The dust extractor must be suitable for the material being worked.

When extracting dry dust that is especially detrimental to health or carcinogenic, use a special dust extractor.

Operation

- ▶ **Before carrying out any work on the power tool (e.g. maintenance, tool change etc.), remove the battery from the power tool.** There is risk of injury from unintentionally pressing the on/off switch.

Operating modes

- ▶ **Remove the battery before carrying out any work on the power tool.**

Setting the cutting depth (see figure C)

- ▶ **Adapt the cutting depth to the thickness of the workpiece.** A space of less than the height of one full tooth should be visible under the workpiece.

Loosen the wing bolt (17). For a smaller cutting depth, pull the power tool away from the base plate (7); for a larger cutting depth, push the power tool towards the base plate (7). Set the required cutting depth on the scale (18). Retighten the wing bolt (17).

When setting the cutting depth, use the reference mark (31) to the side of the cutting depth scale (18).

Adjusting the mitre/bevel angle

We recommend that you place the power tool down on the front side of the protective guard (13).

Loosen the wing bolts (10). Swivel the saw to the side. Set the required mitre/bevel angle on the scale (9). Retighten the wing bolts (10).

When setting the mitre/bevel angle, use the reference mark (27) (upper edge of the holder).

Note: When making mitre cuts, the cutting depth is less than the value shown on the cutting depth scale (18).

Cut Marks

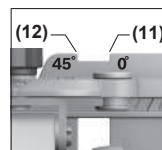

The 0° cut mark (12) indicates the position of the saw blade when making a right-angled cut. The 45° cut mark (11) indicates the position of the saw blade when making a 45° cut.

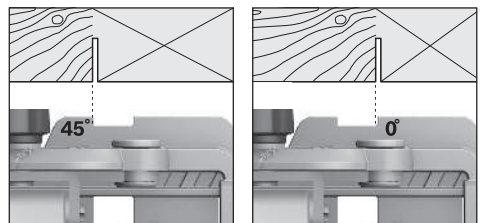

Use the left edge of the cut mark as a guide to make the cut, as shown in the figure. In this case, the waste piece is on the right-hand side. We recommend making a test cut.

Start-up

Switching on/off

To **start** the power tool, first press the lock-off switch **(3)**, **then** press and hold the on/off switch **(4)**.

To **switch off** the power tool, release the on/off switch **(4)**.

Note: For safety reasons, the on/off switch **(4)** cannot be locked; it must remain pressed during the entire operation.

Run-out brake

An integrated run-out brake shortens the time the saw blade keeps running for after the power tool has been switched off.

Switching on the LED worklight

The lamp **(26)** lights up when the on/off switch **(4)** is lightly or fully pressed, meaning that the work area is illuminated in poor lighting conditions.

Practical advice

Protect saw blades against shock and impact.

Guide the power tool evenly, pushing it gently in the cutting direction in order to achieve a high cut quality. Applying too much pressure will significantly reduce the service life of application tools and can damage the power tool.

The sawing performance and the quality of the cut essentially depend on the condition and the tooth shape of the saw blade. This is why you should only use sharp saw blades that are suitable for the material being machined.

Sawing wood

Choosing the right saw blade depends on the wood type, wood quality and whether cuts with or against the grain are required.

Making cuts in spruce with the grain produces long, spiral-shaped chips.

Beech and oak dust is especially detrimental to health. Therefore, work only with dust extraction.

Sawing with a parallel guide (see figure D)

The parallel guide **(32)** allows you to make precise cuts along the edge of a workpiece and cut strips with the same dimensions.

Set the desired cutting width at the outer edge of the base plate using the scale on the guides of the parallel guide/guide rail adapter.

Sawing with an auxiliary guide (see figure F)

For working on large workpieces or for cutting straight edges, you can securely fasten a board or rail to the workpiece as an auxiliary guide. The circular saw can be guided along the path of this auxiliary guide with the base plate.

Sawing with a guide rail (see figure E)

You can use the guide rail **(34)** to produce straight cuts.

Note: Only use the guide rail **(34)** for right-angled cuts. Attempting mitre/bevel cuts could damage the guide rail **(34)**.

The adhesive layer prevents the guide rail from slipping and preserves the surface of the workpiece. The guide rail's coating allows the power tool to glide more easily.

Fasten the guide rail **(34)** to the workpiece using suitable clamping devices, e.g. screw clamps. Put the power tool with mounted guide rail adapter on the guide rail.

Note: Mount the parallel guide/guide rail adapter **(32)** on the power tool with the Bosch logo facing down.

The guide rail (34) must not protrude over the edge of the workpiece being sawn into.

Switch on the power tool and push it gently in the cutting direction, guiding it evenly.

The screw clamp **(33)** can be inserted into the groove of the guide rail **(34)**.

Working with parallel guide/guide rail adapter and extraction hose

First, mount the dust extraction adapter **(29)** with extraction hose **(30)** and then the parallel guide/guide adapter **(32)**.

Note: Use only the intended screws to fix the parallel guide/guide adapter **(32)** and the dust extraction adapter **(29)**.

Maintenance and Service

Maintenance and Cleaning

► **Before carrying out any work on the power tool (e.g. maintenance, tool change etc.), remove the battery from the power tool.** There is risk of injury from unintentionally pressing the on/off switch.

► **To ensure safe and efficient operation, always keep the power tool and the ventilation slots clean.**

The retracting blade guard must always be able to move freely and retract automatically. It is therefore important to keep the area around the retracting blade guard clean at all times. Remove dust and chips with a paintbrush.

Non-coated saw blades can be protected against corrosion using a thin layer of acid-free oil. Remove the oil again before sawing as failure to do so will stain the wood.

Resin or glue residue on the saw blade has a detrimental effect on the quality of the cut. You should therefore clean saw blades straight after use.

After-Sales Service and Application Service

Great Britain

Tel. Service: (0344) 7360109

GB Importer:

Robert Bosch Ltd.
Broadwater Park
North Orbital Road
Uxbridge
UB9 5HJ

You can find the link to our service addresses and warranty conditions on the last page.

In all correspondence and spare parts orders, please always include the 10-digit article number given on the nameplate of the product.

Disposal

Power tools, rechargeable batteries, accessories and packaging should be sorted for environmental-friendly recycling.



Do not dispose of power tools and batteries/rechargeable batteries into household waste!

Only for EU countries and United Kingdom:

Electrical and electronic equipment or used batteries that are no longer suitable for use must be collected separately and disposed of in an environmentally friendly manner. Use the designated collection systems. Incorrect disposal may cause harmful effects on the environment and human health, due to the potential presence of hazardous substances.

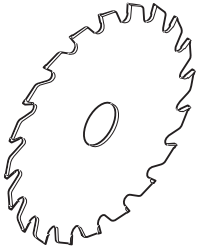

2 608 643 071



1 600 A00 1F8

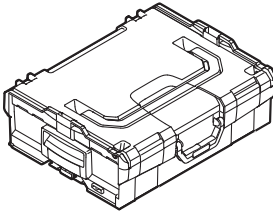

1 605 438 166
(L-BOXX 136)

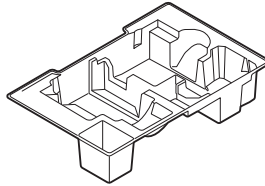

2 608 438 122

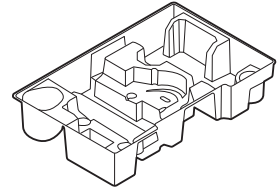

2 608 438 131



Ø 28 mm:
2 608 000 772 (3.2 m)



GAS 18V-12 MC

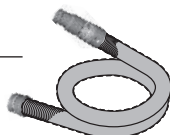
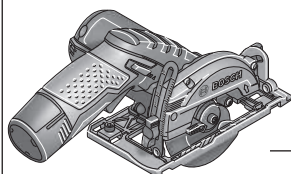

Ø 28 mm:
2 608 000 885 (4 m)



GAS 12-40 MA

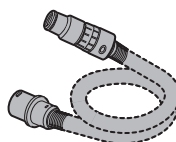

Ø 22 mm:
2 608 000 567 (5 m)

Ø 35 mm:
2 608 000 565 (5 m)



GAS 35 M AFC



GAS 55 M AFC



Ø 22 mm:
2 608 000 568 (5 m)

Ø 35 mm:
2 608 000 566 (5 m)

Servicekontakte
Service Contacts
Contacts de Service
Contactos de Servicio



<https://www.bosch-pt.com/serviceaddresses>

Garantiebedingungen
Guarantee Conditions
Conditions de Garantie
Condiciones de Garantía



<https://www.bosch-pt.com/guarantee/202601>